

## Prewound Bobbin Style Guide

A prewound bobbin's diameter and height is called its "style". Each sewing machine make and model uses a specific bobbin style and will not work with other bobbin styles in most cases.

Sewing machine manufacturers do not make bobbin style information easily available for their products. Fortunately, 90% of U.S. and Canadian machines use one of the five styles shown in the drawings. Overlay your unused bobbin to find the one that you need. If that does not work, use calipers or a ruler and the Prewound Bobbin Style Dimensions at the bottom of the page to get your style.

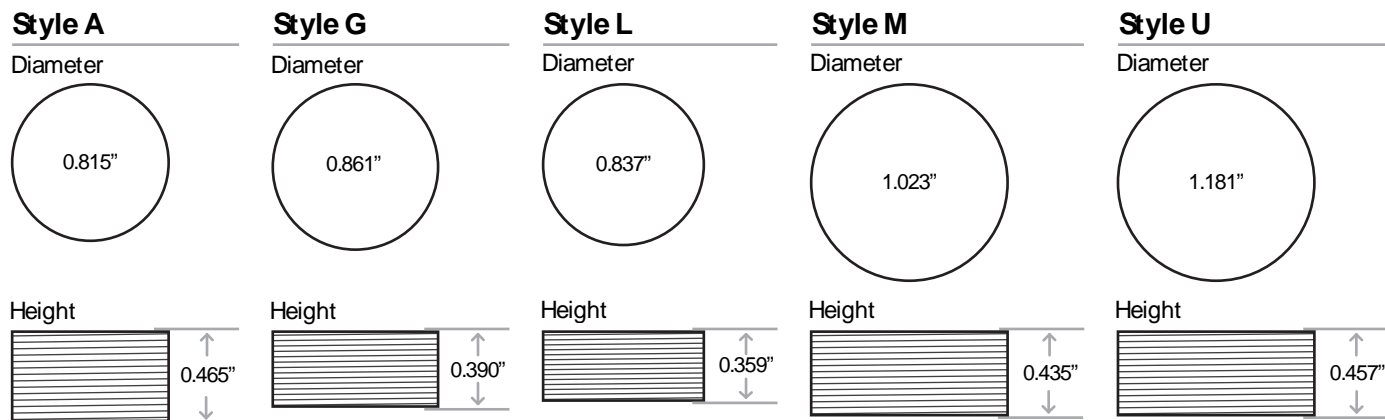

### Prewound Bobbin Style Dimensions

	Inches		Centimeters			Inches		Centimeters	
Style	Height	Diameter	Height	Diameter	Style	Height	Diameter	Height	Diameter
A	0.465	0.815	1.181	2.070	SC	0.465	1.023	1.181	2.598
B	0.441	1.797	1.120	2.024	U	0.457	1.181	1.161	3.000
D	0.295	0.863	0.749	2.192	X	0.485	1.140	1.232	2.896
E	0.380	0.954	0.965	4.423	XSH	0.047	1.258	0.119	3.195
F	0.303	0.986	0.770	2.504	Y	0.500	0.866	1.270	2.200
G	0.390	0.861	0.991	2.187	Z	0.465	0.937	1.181	2.380
H	0.350	0.864	0.889	2.195	ZP	0.485	0.930	1.232	2.362
I	0.301	0.802	0.765	2.037	19	0.242	0.947	0.615	2.405
J	0.430	1.000	1.092	2.540	33	1.195	0.945	30.35	2.400
K	0.301	0.961	0.765	2.441	37	1.065	0.792	2.705	2.012
L	0.359	0.837	0.912	2.126	39	1.197	0.945	30.40	2.400
M	0.435	1.023	1.105	2.598	41	1.740	1.265	4.420	3.213
MA	0.430	1.000	1.092	2.540	55	0.565	1.205	1.435	3.061
P	0.360	0.925	0.914	2.350	57	0.595	1.364	1.511	3.465
R	0.562	0.934	1.427	2.372	58	0.510	1.465	1.295	3.696
S	0.466	1.142	1.184	2.901					